

Installation Manual

PACBRAKE®

www.pacbrake.com 800.663.0096



HP10222 KIT

*NISSAN TITAN 2WD/4WD**

* See application guide for proper fitment.

Use the most advanced air springs on the market to eliminate your vehicle's sag, sway and bottoming out. Pacbrake air suspension levels your truck's stance while providing added support for an overall smooth and safe ride.



KIT CONTENT



Make sure all the items shown in the photo are provided in your kit before starting the installation.

KIT CONTENTS

A	Air Spring	(2)	HP1000D
B	Lower Bracket	(2)	HP1441
C	Passenger Side Upper Bracket	(1)	HP1442
D	Driver Side Upper Bracket	(1)	HP1443
E	Narrow 3/8" U-Bolt	(2)	HP1018
F	Wide 3/8" U-Bolt	(2)	HP1444
G	Clamp Bar	(2)	HP1445
H	3/8" - 16 Nyloc Nut	(14)	HP1000
I	3/8" - 24 X 7/8" Hex Head Cap Screw	(8)	HP1002
J	3/8" Lock Washer	(8)	C18007
K	4" Wire Loom	(2)	M8284
L	3/8" Flat Washer	(24)	C653
M	3/8" - 16 X 7" Carriage Bolt	(4)	HP1409
N	3/8" - 16 X 1.25" Hex Head Cap Screw	(2)	C10464
O	Worm Gear Ring Clamp	(2)	HP1001
P	Air Line Assembly	(1)	HP1344
Q	Tie Straps	(6)	C11618
R	Heat Shield	(1)	HP0012
S	90° Swivel Fitting	(2)	HP1100
T	Tube Cutter	(1)	C3941
U	Roll Plates	(4)	HP10054

REQUIRED TOOLS

- 1/16" Wrench
- 1/16" Socket and Ratchet
- Torque Wrench
- Drill
- Sharp 3/8" Drill Bit
- Hoist or Floor Jack
- Safety Stands
- Safety Glasses
- Spray Bottle with Dish Soap Water Mix

KIT CONTENT

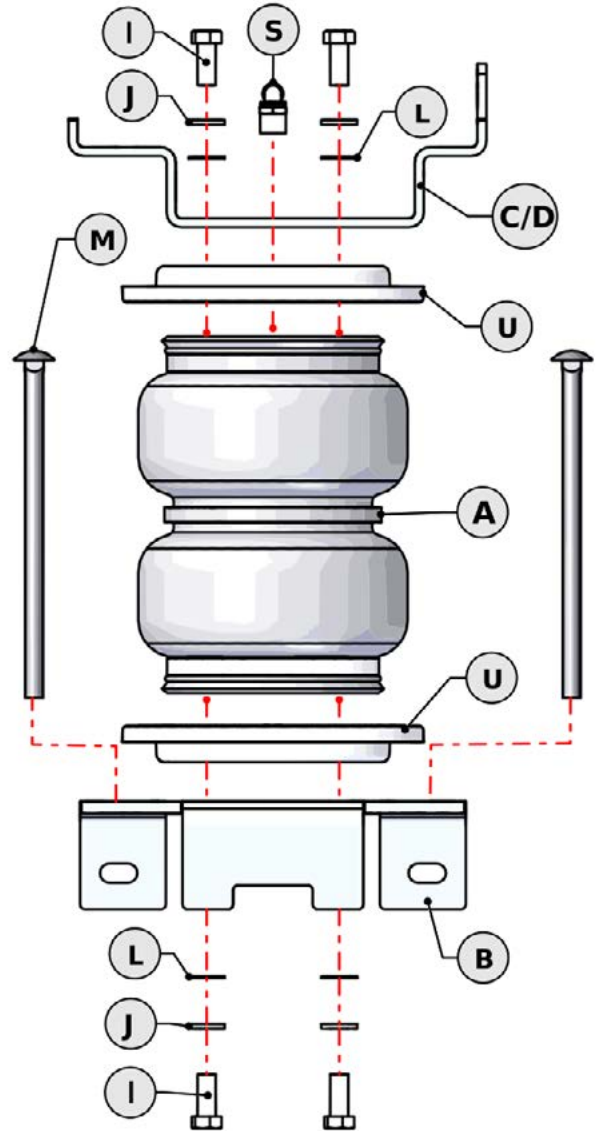
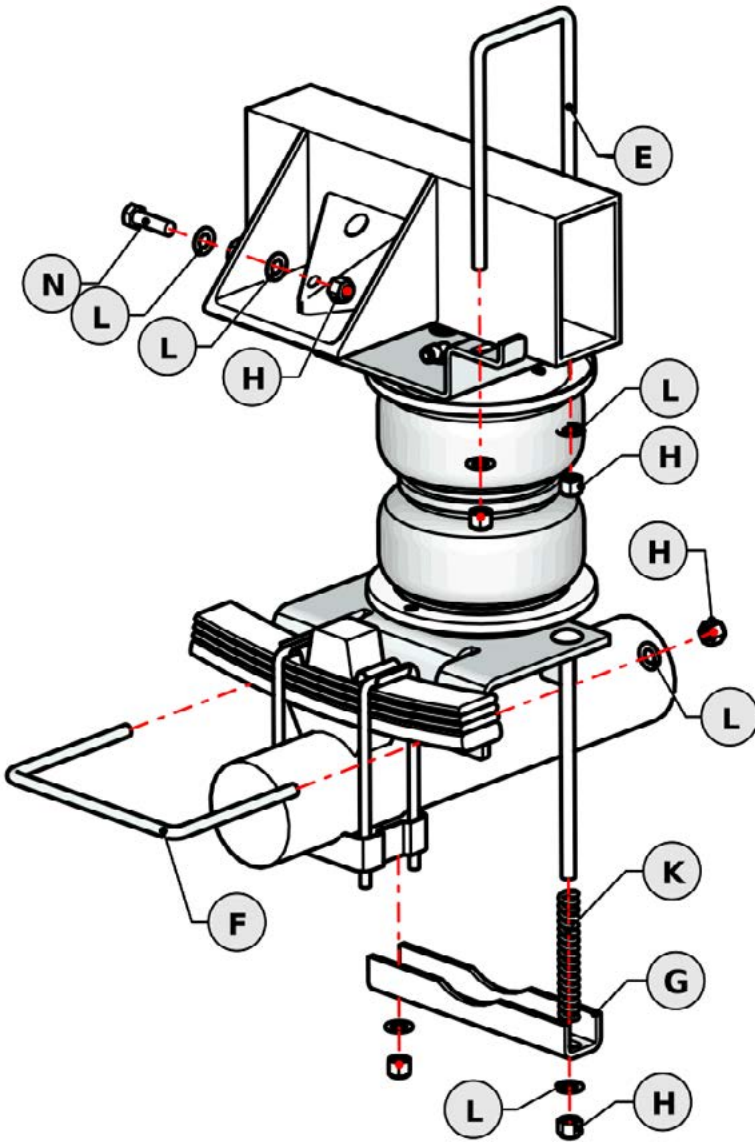

NOTE: Both diagrams are of the left (drivers) side of the vehicle. Reverse any orientations when assembling and installing the right (passengers) side of the vehicle.

Thank you and congratulations on the purchase of an AMP air suspension kit. Please read the entire installation manual prior to starting the installation to ensure you can complete the installation once started.

IMPORTANT:

This air suspension kit will not increase the GVWR (Gross Vehicle Weight Rating), as the GVWR is determined by the axle rating. Do not exceed the maximum capacity listed by the vehicle manufacturer.

BEFORE YOU START:

NOTE: Some vehicles are equipped with a rear wheel brake proportioning valve. Check with the manufacturer before installing the air spring kit, as it may affect braking performance.

1. Ensure the application information is correct for the make, model and year of the vehicle you are installing the kit on.
2. Pacbrake recommends using a good quality anti-seize on all fasteners. This will reduce the chance of corrosion on the fasteners and will help facilitate removal, if required at a later date.

1 RAISE THE REAR AXLE

- Remove any unnecessary weight from the vehicle to attain normal ride height. This is important for correct initial air spring setup and adjustment.
- Park the vehicle on a level surface.
- Record the vehicle's normal ride height, which is the distance between the center of the axle and the horizontal wheel well flange. Ensure both sides are the same before raising the vehicle.
- Raise the rear axle high enough to remove both rear wheels and attain a comfortable working height.
- Place two jack stands under the chassis (photo 1A-1B).
- Lower the floor jack until the vehicle chassis is supported by the jack stands.
- Ensure the normal ride height measurement recorded earlier is the same. Adjust if necessary before proceeding.
- Once the vehicle is raised correctly, remove the rear wheels.

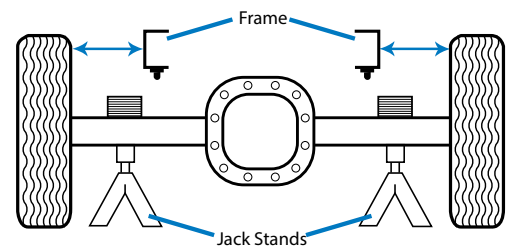

1A



1B

2 PRE-ASSEMBLE THE KIT

STEP A

- Fasten the swivel fitting (S) into the top of the air spring. Finger-tighten and turn an extra 1 turn with a $\frac{1}{16}$ " wrench to tighten.
- Set the roll plate (U) and upper bracket (C or D) over the air spring (A). Ensure that all three holes on the roll plate align with the openings on top of the air spring, see figure 2A.
- Use two $\frac{3}{8}$ " bolts (I), two $\frac{3}{8}$ " lock washers (J), and two $\frac{3}{8}$ " flat washers (L) to fasten the roll plate and upper bracket to the air spring with a $\frac{1}{16}$ " wrench.
- Torque the hardware to 25 ft-lbs (34 N•m) to tighten.

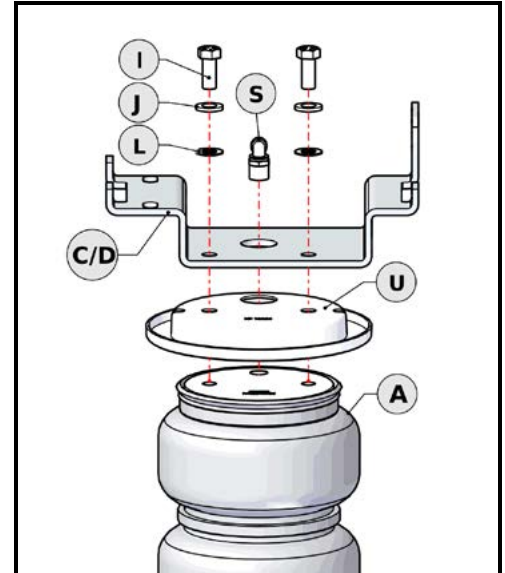

2A

STEP B

- Insert two long $\frac{3}{8}$ " x 7" (M) carriage bolts through the square holes in the lower bracket (B), see figure 2B.
- Place the roll plate (U) and lower bracket (B) underneath the air spring (A), see figure 2C.
- Use two $\frac{3}{8}$ " bolts (I), two $\frac{3}{8}$ " lock washers (J), and two $\frac{3}{8}$ " flat washers (L) to fasten the roll plate and lower bracket to the air spring with a $\frac{1}{16}$ " wrench, see figure 2C.
- Torque the hardware to 25 ft-lbs (34 N•m) to tighten. See the finished assembly, below.
- Repeat for the other air spring.

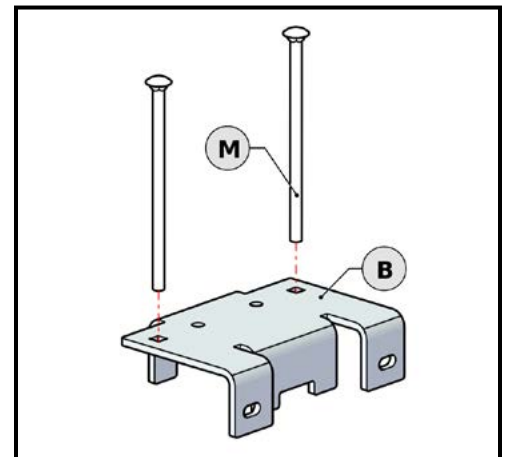

2B

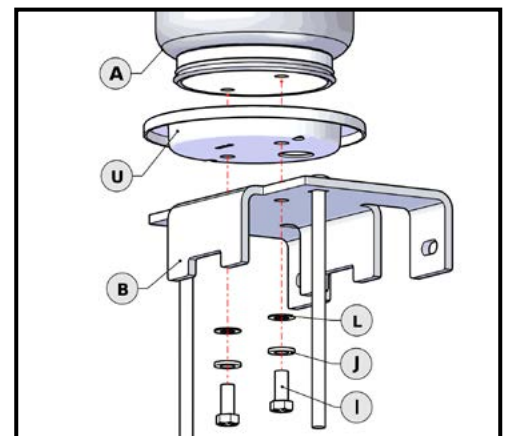
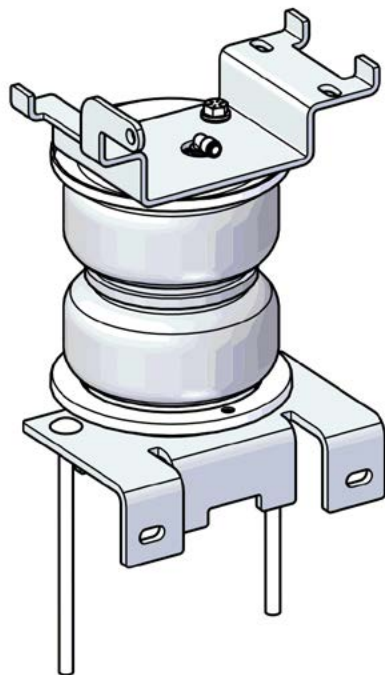

2C

3 INSTALL THE AIR SPRING ONTO THE VEHICLE

STEP A: SECURE THE AIR SPRING ASSEMBLY TO THE AXLE.

- Place the air spring assembly over the axle as shown in figure 3B.
- Guide the wide $\frac{3}{8}$ " U-Bolt (F) around the outside of the leaf stack and through the slots in the lower bracket (B). See figure 3C.
- Use two $\frac{3}{8}$ " nyloc nuts (H) and two $\frac{3}{8}$ " flat washers (L) to fasten the wide u-bolt to the lower bracket. Leave the hardware loose to allow for adjustment. See figure 3C
- Secure the lower bracket to the axle using a clamp bar (G), two nyloc nuts (H), and two flat washers (L). See figure 3D
- Place the wire loom (K) around the rear carriage bolt (as shown in figure 3D) to prevent rubbing against the emergency brake cable.
- Use a $\frac{1}{16}$ " socket to torque all the clamp bar and u-bolt hardware to 16 ft-lbs (22 N•m).

NOTE: The wire loom must be placed on the bolt nearest to the rear of the vehicle. For the drivers side, this will be the right bolt. For the passengers side, this will be the left bolt.

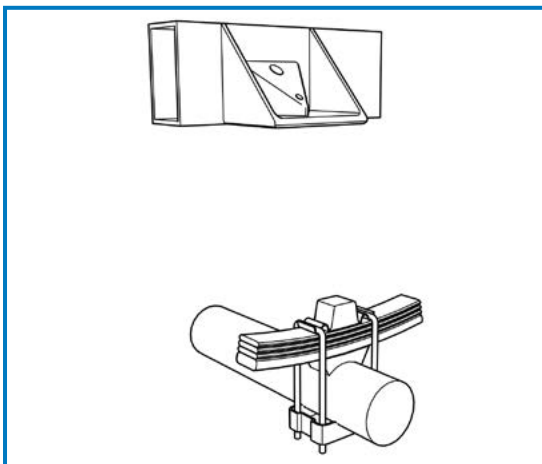

3A

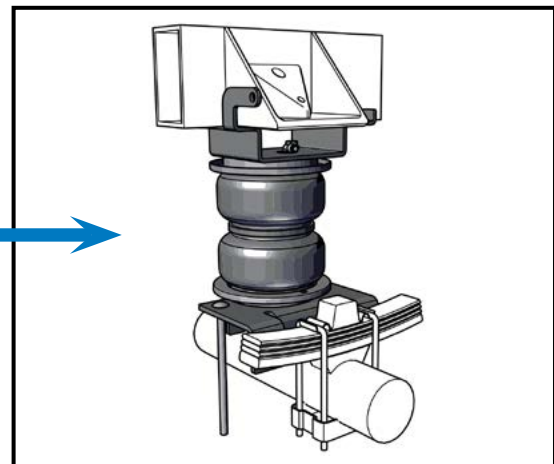

3B

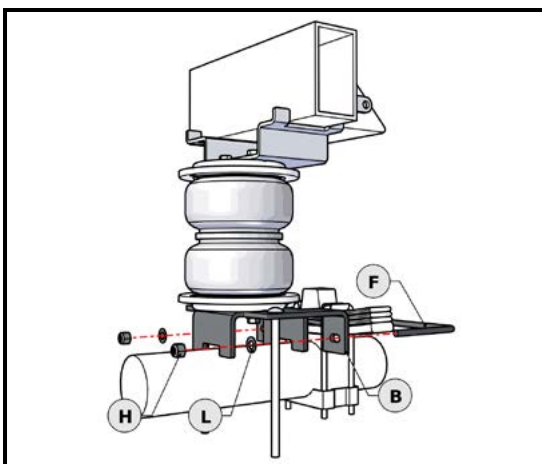

3C

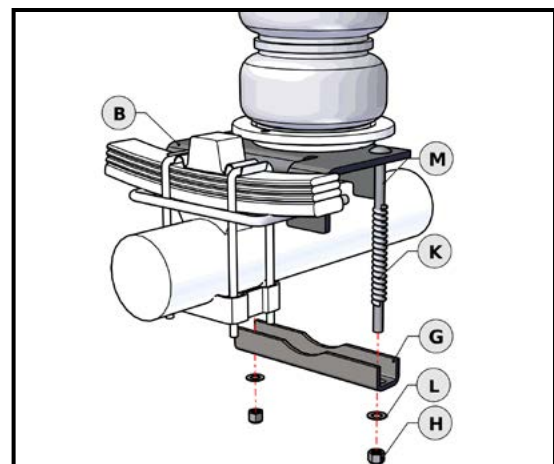

3D

3 INSTALL THE AIR SPRING ONTO THE VEHICLE CONTINUED

STEP B: SECURE THE UPPER BRACKET TO THE FRAME

- Place the narrow u-bolt (E) around the frame rail and fasten it to the upper bracket (C/D) using two flat washers (L) and two 3/8" nyloc nuts (H). See figure 3E.
- Use a 9/16" socket to torque the u-bolt hardware to 25 ft-lbs (34 N•m).
- With the rest of the assembly secured in place and using the upper bracket as a guide, drill a 3/8" hole through the jounce stop as shown in figure 3F.
- Secure the upper bracket in place with a 3/8" bolt (N), two flat washers (L), and a nyloc nut (H). See figure 3G.
- Use a 9/16" socket to torque the bolt to 25 ft-lbs (34 N•m)
- The installation is complete for this side. Reverse any orientations and repeat steps 2-3 on the opposite side.

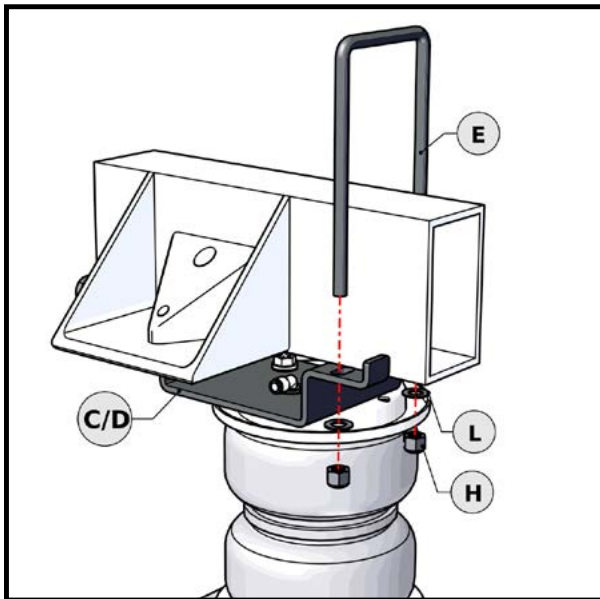

3E

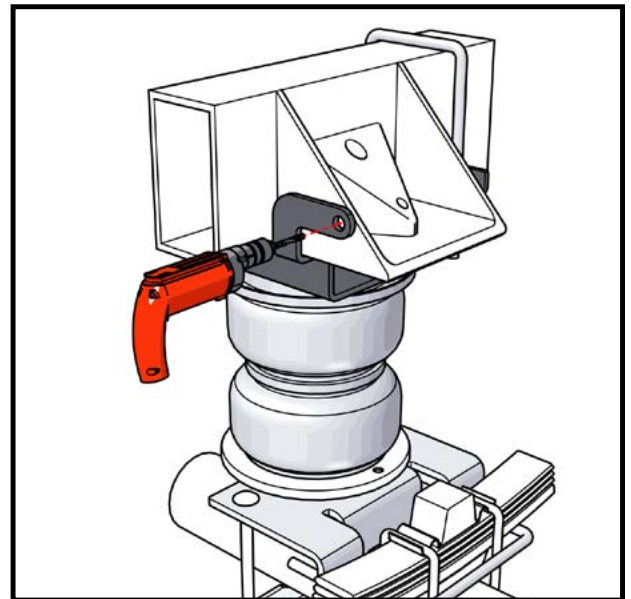

3F

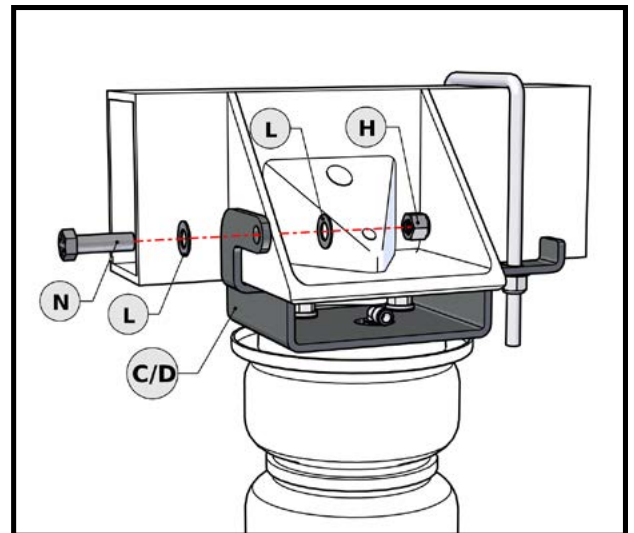

3G

4 INSTALL THE HEAT SHIELD

- Bend the tabs on the heat shield so there will be the necessary 1/2" dead space between the heat shield and the muffler when the heat shield is attached.
- Attach the heat shield to the exhaust pipe on the passenger side using two hose clamps. Each hose clamp holds a tab against the exhaust pipe. Make sure the heat shield is facing toward the air spring.



4A

5 INSTALL THE AIR LINE

- Provided in the basic air spring kit are two fill valves attached to an airline (P). The most common place to install them is to replace the license plate fasteners with the fill valves. Alternatively, two 5/16" holes can be drilled in a convenient location. Install one airline provided, route the nylon hose to an air spring fitting, cut the hose and connect to the air spring fitting. Repeat with the other fill valve.
- Secure airlines with the tie-straps provided away from moving items and heat sources.
- If an in cab inflation kit is being installed, follow the instructions provided with it.

NOTE: This kit contains push-to-connect fittings, using scissors or wire cutters to cut the nylon airline will distort the line and cause the connection to leak. **THE AIRLINE MUST BE CUT OFF SQUARELY WITH A SHARP RAZOR KNIFE OR THE NYLON HOSE CUTTER (T) PROVIDED IN THE KIT.**

- Moisten the end of the airline prior to inserting it into the fitting and push it in until it stops.
- After the airline is cut, insert one end into the air line fitting, as shown in photo 5B and the other into the fill valve. Moisten the end of the air line with liquid soap prior to inserting it, and then push it in until it stops.



5A



5B

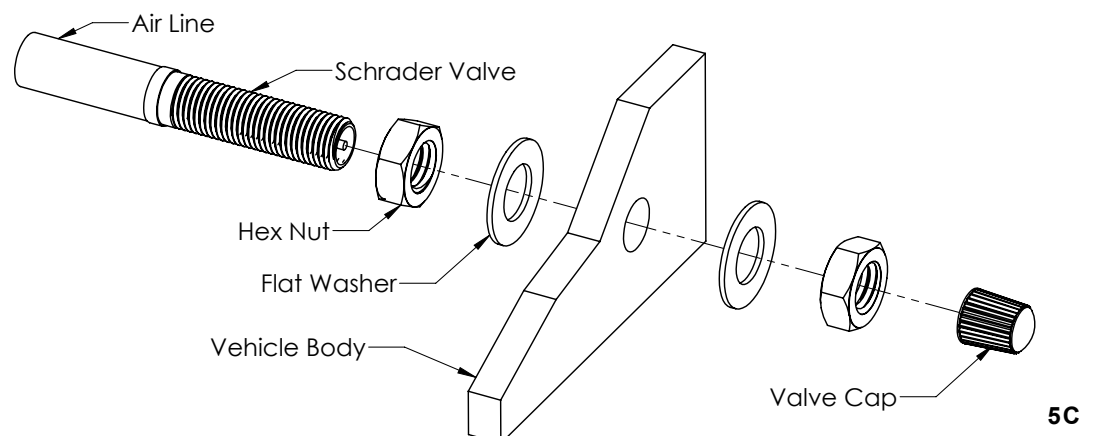

5C

6 CHECK SYSTEM FOR LEAKS

- Inflate both air springs to 90 PSI, and then use a mixture of dish soap and water on all air line connections to detect any air leaks. Repair as necessary and retest.
- Inflate the air springs to a predetermined value, and on the following day recheck the pressure. If one or both the air springs have lost pressure, an air leak is present. The leak must be repaired, and then retested until no leaks exist.



6A

7 AFTER THE INSTALLATION IS COMPLETED, PLEASE REMEMBER

- Install the wheels, and torque the fasteners to the manufacturer's specifications.
- Re-torque all the fasteners after the first 500 miles of driving.
- For safe and proper operation, never operate the vehicle under the minimum of 10 PSI or over the maximum of 100 PSI. Staying within the pressure limit will ensure maximum air spring life. Failure in doing so may result in a void warranty

OPTIONAL ACCESSORIES

Pacbrake offers an optional dual needle air gauge to monitor the pressure in each spring from the vehicles cab. Pacbrake offers a full line of air compressors, air tanks and solenoids to control your air spring system.

OPERATING YOUR VEHICLE WITH PACBRAKE AIR SUSPENSION

Air springs have minimum and maximum pressure requirements. Never operate your vehicle with less than 10 PSI in the air spring and never inflate the air springs over 100 PSI. Damage to the air springs will result.

Check the air pressure in the air springs daily for the first couple of days to ensure a leak does not develop. The air springs are designed to maintain the vehicles stock ride height with a load. Do not use the air springs as a means to lift the vehicle with no load. A rough ride will result.

SERVICING YOUR VEHICLE WITH PACBRAKE AIR SUSPENSION

When lifting the vehicle with a floor jack or hoist on the frame, never allow the air spring to limit the travel of the axle. Try to always jack the vehicle on the axle. Suspending the axle with the air spring limiting the axle travel will damage the air spring and void the air spring warranty.

WARRANTY

To be eligible for warranty, owner must submit their warranty card or register online within 30 days of purchase date.

NOTE: The owners warranty will be void if air springs run with less than the minimum of 10 PSI.