

Pacbrake Exhaust Brake Wiring Schematic For:

INTERNATIONAL 4700/4900 MODELS 444E/DT466E/DT530E NAVPAK SYSTEMS

For vehicles: (WITH) Allison 1000/2000/2400 Transmissions (WITH or WITHOUT) ABS Braking (WITH) On-board air supply

Note: Do not use on vehicles equipped with **Allison 4th Generation Transmissions**, they are identified by one connector at the transmission ECU, consult Pacbrake factory

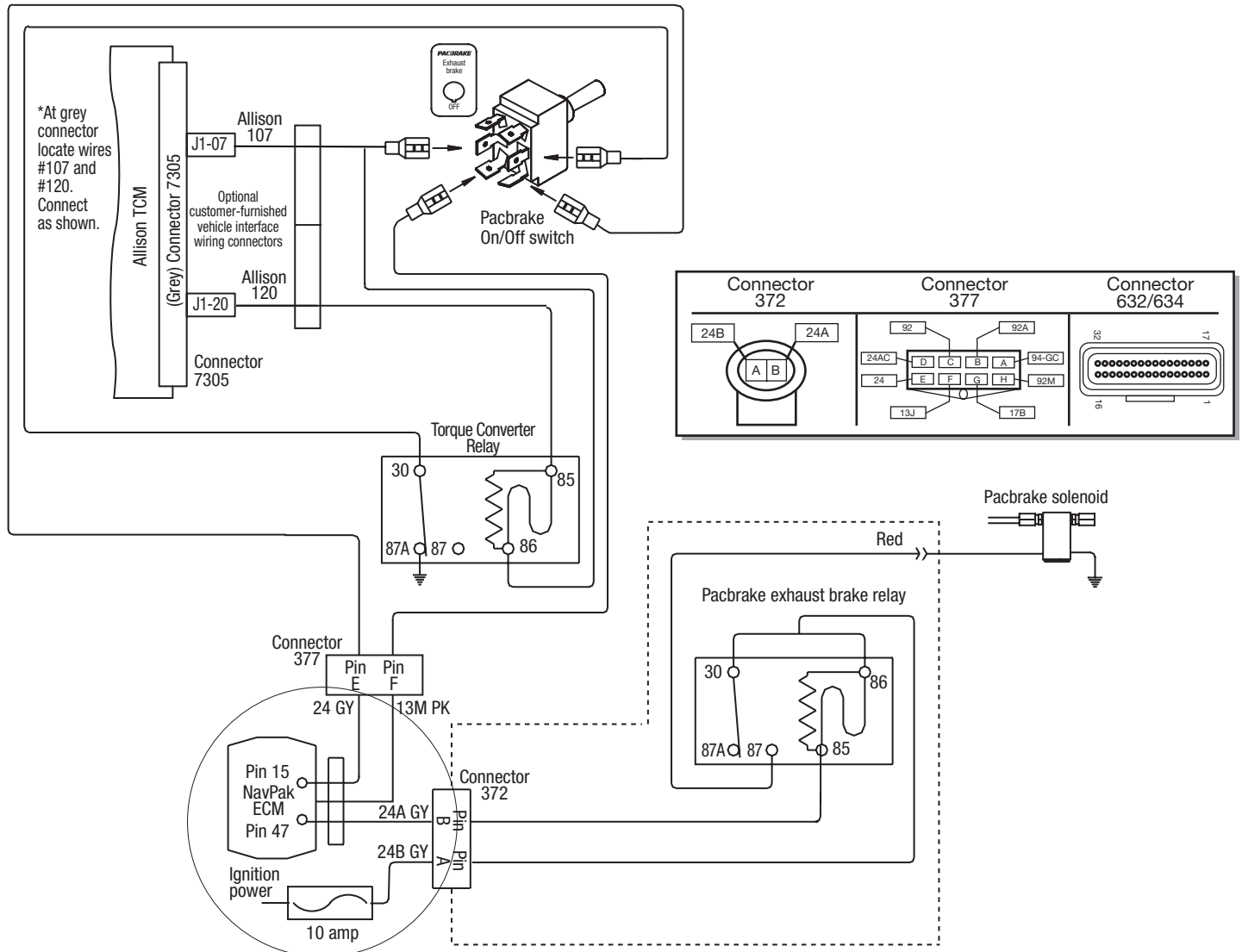

NOTE:

- Pacbrake wiring kit contains toggle type switch, source Navistar rocker switch part number 1677051 if desired.
- Dotted area indicates Pacbrake harness PN11804.
- Navistar supplied wires illustrated in circled area.
- Relays shown are de-energized.
- Connector 372 located above starter on DT 466 and DT530. On 444E it is located behind the cylinder head drivers side. Remove protective cap and connect to pacbrake harness (supplied).
- 8 Pin connector 377 located behind fuse panel
- Connector 7305 located at Allison ECU.
- The NavPak ECM requires exhaust brake circuit to be enabled.
- Updates or variations by vehicle manufacturers constituting changes will not be the responsibility of Pacbrake.
- Information for this schematic was derived from vehicle systems at the date of this printing.