

P-63C

ENGINE BRAKE PARTS GUIDE

APPLICATION | DETROIT DIESEL SERIES 60

/// PAC BRAKE®

P-63C - P60006 HOUSING ASSEMBLY

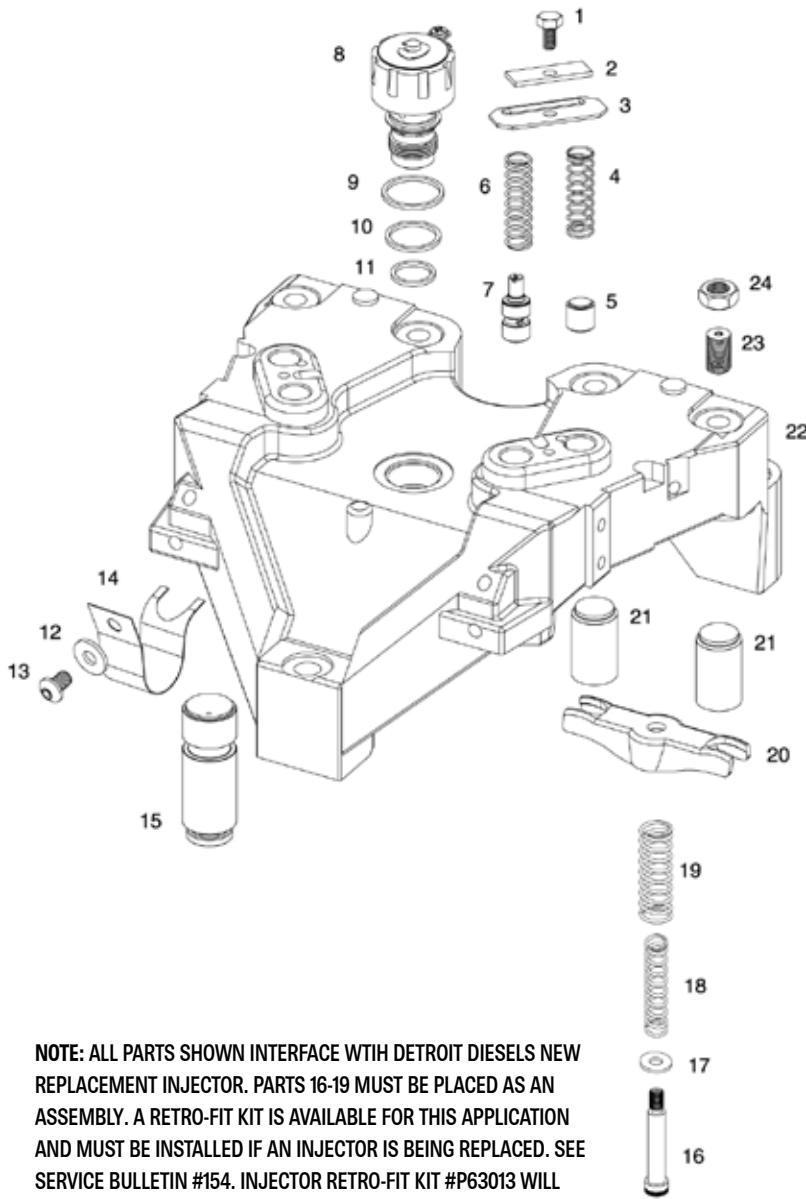

NOTE: ALL PARTS SHOWN INTERFACE WITH DETROIT DIESELS NEW REPLACEMENT INJECTOR. PARTS 16-19 MUST BE PLACED AS AN ASSEMBLY. A RETRO-FIT KIT IS AVAILABLE FOR THIS APPLICATION AND MUST BE INSTALLED IF AN INJECTOR IS BEING REPLACED. SEE SERVICE BULLETIN #154. INJECTOR RETRO-FIT KIT #P63013 WILL UPDATE 3 HOUSINGS.

#	PART #	DESCRIPTION	QTY
1	P01492	CAPSCREW-1/4X1/2 HEXHEAD	2
2	P60019	SPRING PLATE	2
3	P34650	CONTROL VALVE COVER	2
4	P60061	ACCUMULATOR SPRING-RED	2
5	P60060	ACCUMULATOR PISTON	2
6	P60053	CONTROL VALVE SPRING-BLUE	2
7	P01500	CONTROL VALVE	2
8	P04205	SOLENOID-12VOLT	1
9	P01081	SOLENOID SEAL-UPPER	1
10	P01082	SOLENOID SEAL-CENTER	1
11	P01083	SOLENOID SEAL-LOWER	1
12	P38015	PLAIN WASHER	2
13	P03795	CAPSCREW-1/4-20 X 1/2	2
14	P60013	FLAT SPRING	2
15	P60064	MASTER PISTON-7/8" O.D. ORIFICE	2
16	P60096	SHOULDER BOLT	2
17	P60086	SPRING RETAINER WASHER	2
18	P60090	INNER SLAVE SPRING	2
19	P80090	OUTER BRIDGE SPRING	2
20	P60070	SLAVE PISTON BRIDGE	2
21*	P60004	OUTER SLAVE PISTON-13/16 O.D. 13/16"	4
22	N/A	BARE HOUSING	
23	P60073	PAFLASH ADJUSTING SCREW - NATURAL 0.023" PROT.	4
24	P09355	JAMNUT 1/2 NF	4
Ni.	P60006	ENGINE RETARDER HOUSING-P63C	3
Ni.	P60101	TUNE UP KIT-P61/P63/A/B/C (SOLD SEPARATELY)	

*SHORTER SLAVE PISTONS FOR ENGINES WITH RE-MAN CYLINDER HEADS.

#	PART #	DESCRIPTION	QTY
21	P60065	SLAVE PISTON - OUTER	4 p/Hsg

BASE KITS FOR P-63C - P63008

DIAGRAM #	PART #	DESCRIPTION	QTY
1	P60010	ENGINE RETARDER HOUSING-P61	3
2	P60023	SPACER BAR	2
3	P60050	ATTACHING PARTS GROUP P61/P63	1

ATTACHING GROUP FOR P-61/P-63C - P60050

DIAGRAM #	PART #	DESCRIPTION	QTY
1	P60021	CAPSCREW-12PT	9
2	P60022	WASHER	9

OPTION ITEMS FOR P-61/P-63C

DIAGRAM #	PART #	DESCRIPTION	QTY
1	P12261T	WOBBLE SWITCH & BRACKET GROUP	1
2	P11494	SOLENOID SOCKET	1
3	P60085	HARNESS EXTENSION-COE, DDEC II	1

CONTROL GROUPS FOR P-61/P-63C WITH DDEC II - P60150

DIAGRAM #	PART #	DESCRIPTION	QTY
1	P02970	TOGGLE SWITCH ASSEMBLY	1
2	P01304	TOGGLE SWITCH - ON/OFF	1
3	P01305	SWITCH PLATE-OFF	1
4	P01495	CLUTCH SWITCH ASSEMBLY	1
5	P60045	RELAY-12 VOLT CN	1
6	P60100	SELF DRILL & TAP SCREW	1
7	P01300	FUSE HARNESS	1
8	P60014	TIE-STRAP	12
9	P60046	HARNESS-DDEC	1
10	P60047	HARNESS-THRU HEAD	1
11	P60048	HARNESS-UNDER COVER	1
12	P64206	SOLENOID TERMINAL	3

CONTROL GROUPS FOR P-61/P-63C WITH DDEC III/IV - P60155

DIAGRAM #	PART #	DESCRIPTION	QTY
1	P02970	TOGGLE SWITCH ASSEMBLY	1
2	P01304	TOGGLE SWITCH - ON/OFF	1
3	P01305	SWITCH PLATE-OFF	1
4	P60014	TYWRAP	12
5	P60048	HARNESS-UNDER COVER	1
6	P60049	JUMPER WIRE-P63	1
7	P60063	HARNESS-THRU HEAD, DDEC III	1
8	P64206	SOLENOID TERMINAL	3
9	M8069	PUSH-ON TERMINAL	3

MOST VEHICLES WITH DDEC III OR DDEC IV ARE PRE-WIRED AT THE VOEM PLANT. IS THE VEHICLE IS NOT PRE-WIRED, CONTACT THE APPROPRIATE VOEM FOR THE CAB HARNESS

